

FIREMASTER® & SMOKESTOP CONCERTINA™

CONCERTINA™ - THE MULTI-SIDE ACTIVE FIRE
AND SMOKE CURTAIN BARRIER ASSEMBLY

WWW.COOPERSFIRE.COM



coopers

EST. 1983

LEADING THE WAY IN FIRE PROTECTION

DESIGN SOLUTIONS THAT WORK FOR YOU

The FireMaster® and SmokeStop Concertina™ offer solutions to modern day open plan building designs to prevent the spread of fire and smoke.

The innovative design of the Concertina fire curtain and smoke curtain allows it to be used in a variety of applications in different building types, removing the requirement for columns or corner posts and intrusive ceiling interfaces that may be required for alternative fire and smoke safety products.

The FireMaster Concertina is tested to different test regime standards as the SmokeStop Concertina meaning the FireMaster Concertina should be used to prevent the spread of fire with smoke control whereas the SmokeStop Concertina should be used to contain or channel smoke. For more information on this subject, contact Coopers Fire.

The Concertina can be configured in a variety of bespoke sizes and shapes, like a square or circle and an arc or trapezoid. In fact, the Concertina can be configured in most shapes in unlimited spans.

To be compliant, Fire and Smoke Curtains must be protected from a short circuit, system corruption and or total power failure, this is achieved with our patented Total Gravity Fail Safe (TGFS) system.

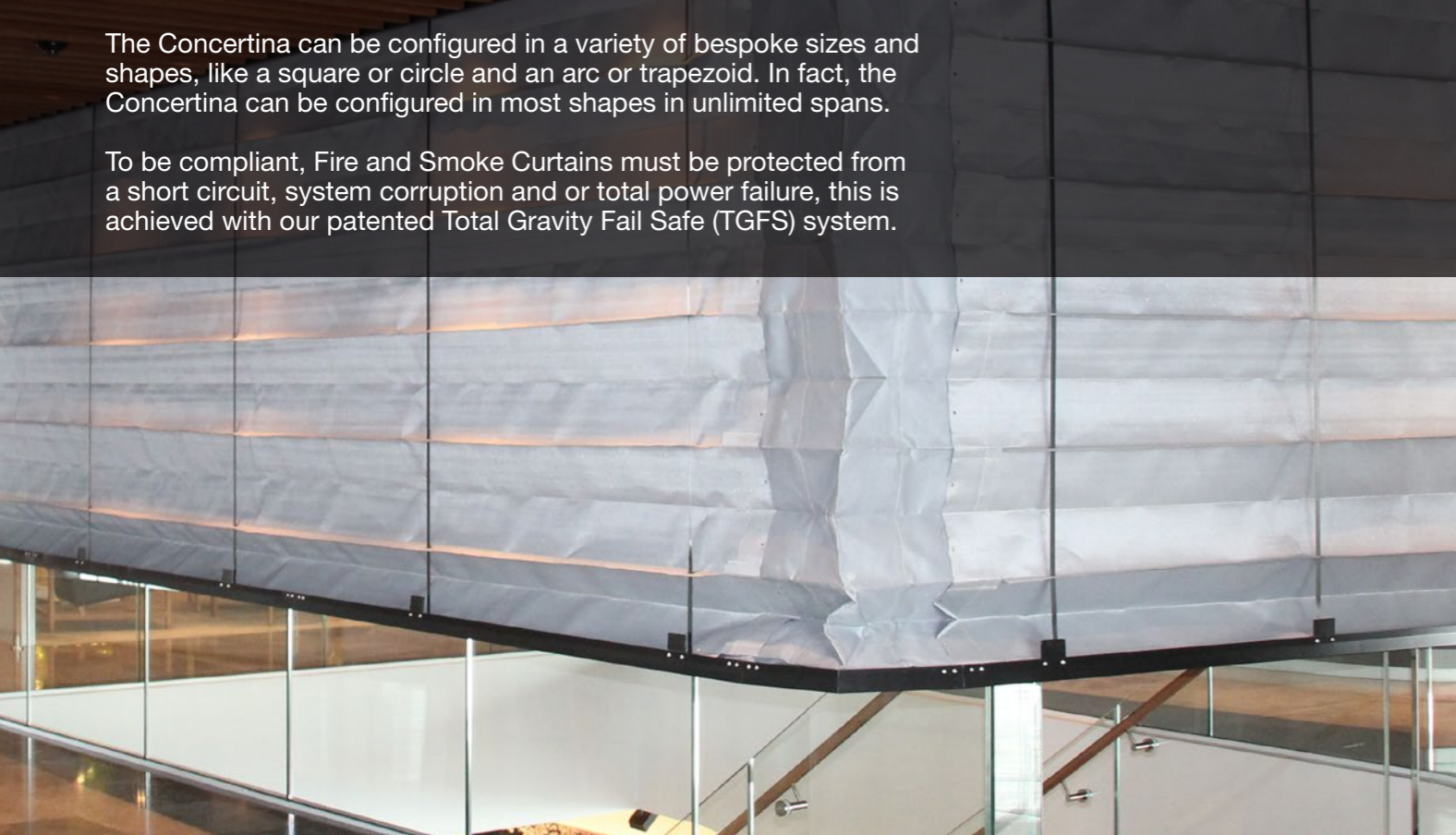

PRODUCT ADVANTAGES

• **NO MORE COLUMNS AND CORNER POSTS**

With no visible support posts required, the Concertina offers open plan environments.

• **NO MORE INTRUSIVE SIDE GUIDES**

No corner posts and columns means that there is no longer the need for side guides to compromise design.

• **NO MORE INTRUSIVE CEILING INTERFACES**

Our ceiling interfaces are designed to blend with your existing ceiling, resulting in a discrete and aesthetically pleasing finish.

• **INCREASE FLOOR SPACE**

Free up space that's usually occupied by rated glass or non-loadbearing compartment walls.

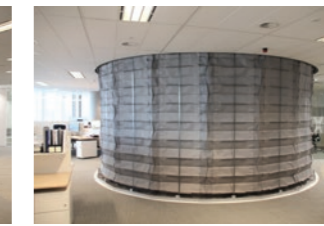
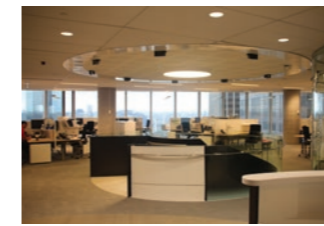

OPEN SPACE

- Virtual compartments with unlimited width for maximum design flexibility

ESCALATORS

- No need for non-loadbearing fire-rated walls

ATRIA

- Allows multi-floor concourse openings for large atria

STAIRWELLS

- No need for non-loadbearing fire-rated walls

LOBBIES

- No need for non-loadbearing fire-rated walls and doors



DON'T BE LIABLE

Fire and Smoke Curtain Barriers MUST have a 'Total' Fail-Safe by Gravity* in the event of total mains wiring, short circuit and/or system corruption.

Coopers Fire, with their unique patented Total Gravity Fail-Safe (TGFS) system, are the only supplier with Independent Third Party Certification by a UKAS approved certification body and now meets essential requirements of BS 8524-1:2013 and BS 8524-2:2013.

• **INCREASE INCOME**

Maximising floor space by opening up spaces will increase square meter yield and rental income.

• **ANY SHAPE**

Every Concertina is bespoke and is manufactured to meet your specific requirements.

• **TOTAL GRAVITY FAIL-SAFE (TGFS)**

operation ensures safe rates of descent even following total power loss, wiring, short circuit or system

CASE STUDY: OIL SEARCH

SYDNEY AUSTRALIA

Ensuring you remain protected from fire without compromising the intended architectural open plan design can be problematic, especially when you're protecting stairwells and atria.

Such a situation led Oil Search Australia to employ Coopers Fire to develop and manufacture a unique circular 18-sided Concertina™ that ensures the office complies with stringent Building Code requirements whilst permitting an imposing and more efficient office space overlooking Sydney Harbour.

The revolutionary Concertina™ design arrangement protects the open plan spiral staircase whilst removing the need for side guides and columns to provide the full fire rating. The end product provided a uniform look across all 3 levels, mirroring the spiral staircase opening.

We have also installed L shaped and four/sided configurations of the Concertina™ into Selfridges, Oxford St and Bovis Lend Lease, London.

BENEFITS

- Only one product/system is required to achieve the required fire rating.
- No side guides, no columns and no posts.
- A curved ceiling interface panel fits in with the look and feel of the building.
- No compromise on the fire performance.
- Interfaces with the zone smoke control system.
- Modular construction that's quick to install.
- No secondary steelwork required.
- Multi-functional operation.

CONCERTINA

The revolutionary FireMaster® Concertina™ provides the same protection as a steel fire shutter but at a fraction of the size and weight, with no need for columns, corner posts, side guides and intrusive ceiling interfaces.

The FireMaster Concertina offers architects, specifiers and owner/occupiers a whole new way to approach building design, maximising floor space and increasing rental income.

Active Fire Smoke Curtain Barrier Assemblies comprise technologically advanced fire-resistant fabric barriers encased in a compact steel housing. Barriers remain invisibly retracted until activated by an alarm or detector signal, at which time they descend safely to their operational position.



CONCERTINA DH60

The Coopers SmokeStop® Concertina™ is a multi-sided smoke curtain that removes the requirement for columns or corners posts. It is available in unlimited widths and available in various shapes to suit different building applications.

The unique features of the SmokeStop Concertina allow architects, fire engineers and specifiers to create open plan designs and act as part of the smoke control strategy within buildings.

The fire resistant fabric used in the Concertina assist the channeling or containment of smoke and is innovatively folded to allow the fabric to stack neatly into the compact steel headbox, which falls perfectly when the smoke curtain is deployed.

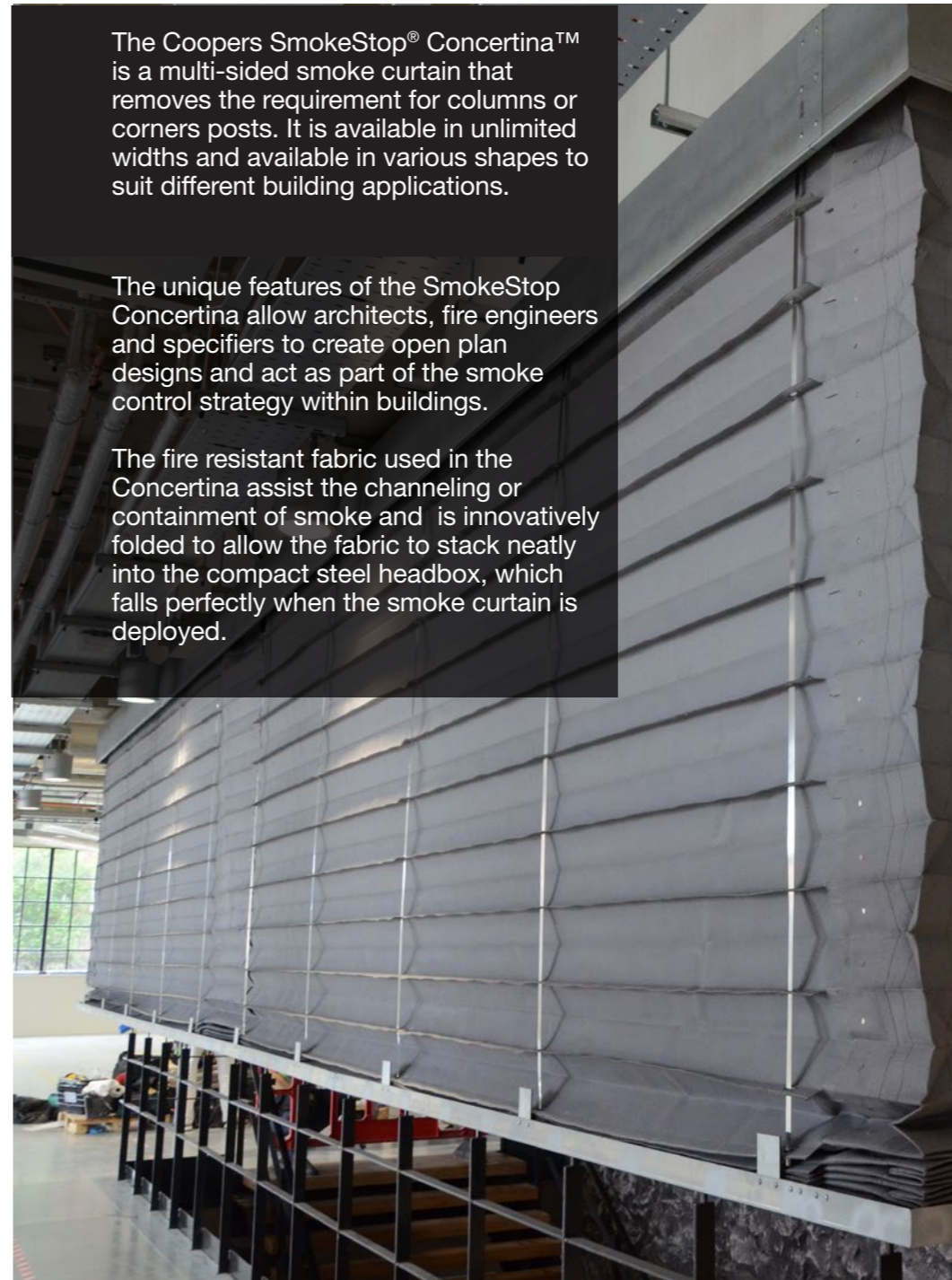

PRODUCT FEATURES

COMPLIANT TO BS 8524:2013-1

CLASSIFICATION

FIREMASTER CONCERTINA CLOSED

E120 EW30 MAX WIDTH: UNLIMITED MAX HEIGHT: 8 METRES
E240 EW30 MAX WIDTH: UNLIMITED MAX HEIGHT: 5 METRES

FIREMASTER CONCERTINA OPEN

E120 EW30 MAX WIDTH: UNLIMITED MAX HEIGHT: 8 METRES
E180 EW30 MAX WIDTH: UNLIMITED MAX HEIGHT: 5 METRES

PRODUCT FEATURES

COMPLIANT TO BS EN 12101-1:2005+A1:2006

CLASSIFICATION

SMOKESTOP CONCERTINA - DH60 / D60

MAX WIDTH: UNLIMITED MAX HEIGHT: 6 METRES

BESPOKE PRODUCT CONFIGURATIONS

Developed to provide a bespoke alternative to fixed non-loadbearing walls and partitions, the Concertina can be used as part of a fire engineering solution to protect a building and its occupants from the effects of fire and smoke. It can be used in commercial, domestic and industrial applications such as airports, shopping centres, offices and hotels or where the need for maintaining open areas for access is vital.

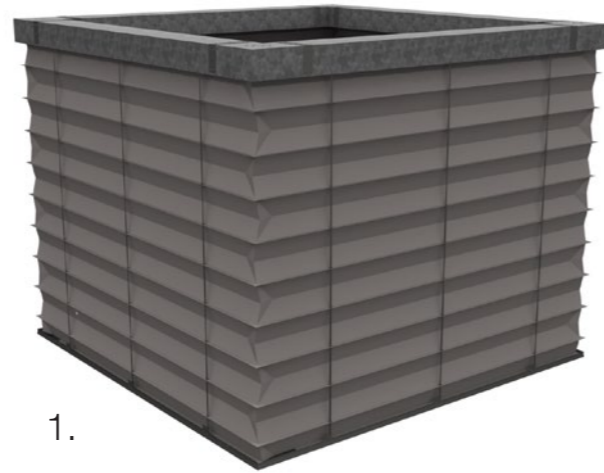

1.

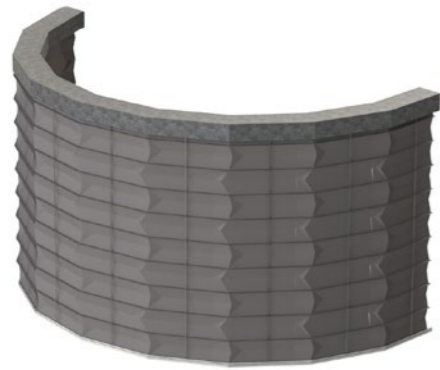

2.



3.

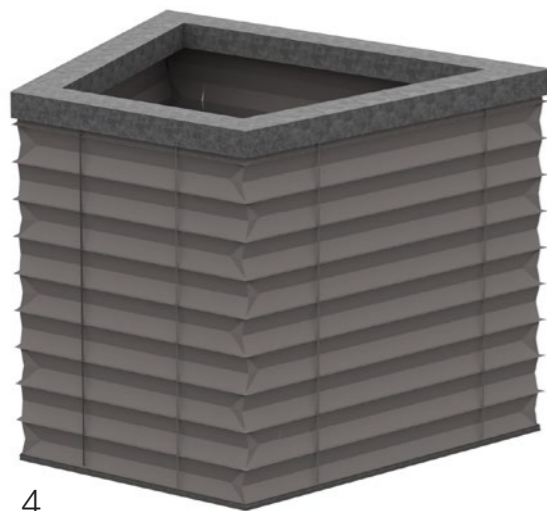

4.



5.

- 1. Square (Closed)
 - 2. Faceted Curve (Open)
 - 3. L Shaped Corner (Open)
 - 4. Trapezoid (Closed)
 - 5. Multisided (Closed)
- Barriers up to 5m in height have been approved for 4 hours (240 mins) fire-resistance integrity. For barriers up to 8m high, are approved for 2 hours (120 mins).

HEADBOXES

STANDARD HEADBOX SIZES

Coopers has a design solution for any size requirement. For queries about special size requirements, please contact our technical department.

Model No.	Maximum Barrier Width	Maximum Barrier Drop
FM Concertina 35/22	Unlimited	Up to 4m
FM Concertina 35/35	Unlimited	4m - 8m
SS Concertina 35/22	Unlimited	Up to 4m
SS Concertina 35/35	Unlimited	4m - 6m

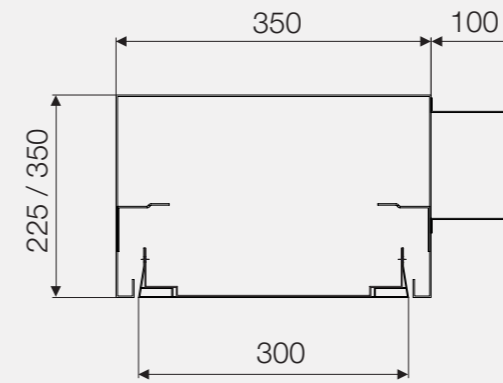

Headbox Section (motor on RH)

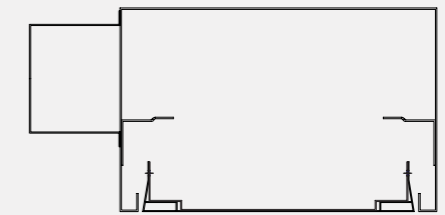

Headbox Section (motor on LH)

COMPACT HEADBOX SIZES

Coopers has a design solution for any size requirement. For queries about special size requirements, please contact our technical department.

Model No.	Maximum Barrier Width	Maximum Barrier Drop
FM Concertina 22/27	Unlimited	Up to 3m
SS Concertina 22/27	Unlimited	Up to 3m

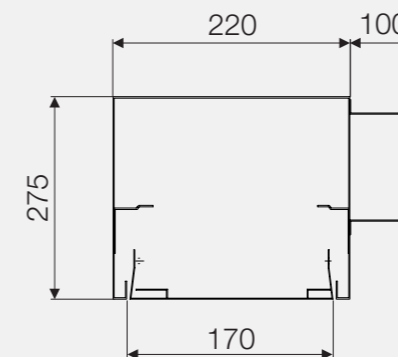

Headbox Section (motor on RH)

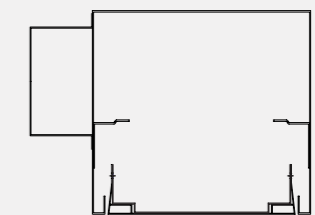

Headbox Section (motor on LH)

SIDE CHANNELS WITH THE OPEN CONCERTINA

WHAT IF I NEED SIDE CHANNELS

With open shapes it's also possible to install the Concertina™ to work with traditional side retention systems whereby the barrier is fixed to the building and can be either surface mounted or recessed into the wall structure to give a flush finish.

The diagrams below illustrate both Recessed and Face Fix options.

Coopers' unique fabric locking system has been developed and proven over many years.



Plan View of Side Guide

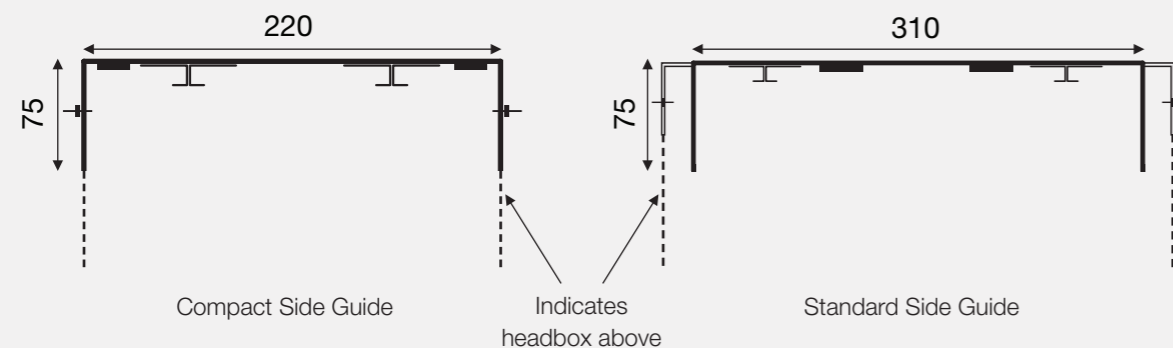

MULTI-FACETED CEILING INTERFACES

Coopers Fire can offer ceiling interfaces with the Concertina, allowing for the fire or smoke curtain to be unobtrusive and inconspicuous in various applications in different building types.

The ceiling interface can be part of a bespoke engineered design (price on application).

Materials used for the ceiling interface trim can be MDF, plywood, fiberglass, aluminium, steel or other lightweight materials.

Weight restrictions for ceiling interface materials will apply due to the requirement for the curtain to be held open by way of an electro-magnetic brake.



With multi-faceted circular or arc shaped ceiling interfaces, it must be considered that the greater number of facets that make up the Concertina allow for more acute angles. This in turn allow the ceiling interface to be thinner in width.

This is illustrated in the diagrams to the right.

PLEASE NOTE:
Ceiling interfaces are an optional extra not included in the price unless requested.

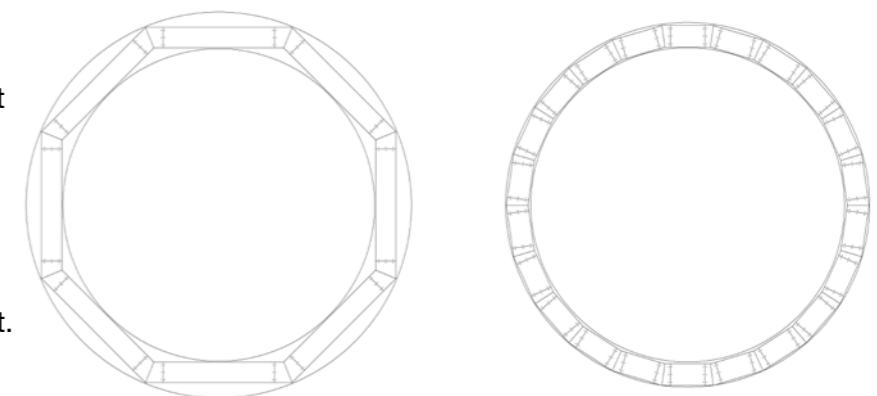

Multi-faceted Concertina

HOW ARE THE BARRIERS CONCEALED?

We can provide a range of ceiling interface trims developed to conceal the barrier in the ceiling whilst still allowing access for service and maintenance. All our systems remain totally concealed when non-operational. With suspended ceilings, our unique patented Coopers' system SLAT™ (Self Levelling Access Trim) can be utilised.

Remember, regular service and maintenance is a legal mandatory requirement.

ALTERNATIVE CEILING INTERFACE



HOW ARE THE HEADBOXES INSTALLED?

There are many fixing options to suit all types of ceiling configurations. Barriers can be integrated with both solid and suspended ceilings, enabling total project design flexibility.



CONTROL OPTIONS

Controls are custom made to be fully compatible with both existing alarm systems and the number of barrier units installed, whether single or multiple roller assemblies.

When an alarm signal is detected, the control panel will automatically trigger all the Barrier systems to deploy by controlled descent using our unique Total Gravity Fail-Safe (TGFS) system.

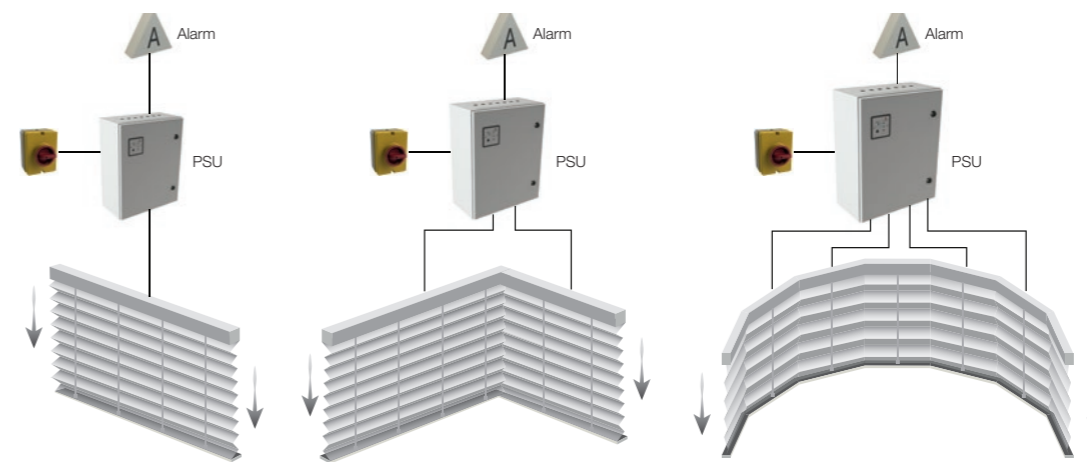

PRODUCT SPECIFICATIONS

FIREMASTER CONCERTINA CLOSED

The complete system is tested and assessed in accordance with BS EN 1634-1:2014 as required by BS 8524-1:2013 for 240 minutes Integrity, and 30 minutes Radiation.

Classified as E240 EW30 C1 in accordance with BS EN 13501-2:2007+A1:2009.

FIREMASTER CONCERTINA OPEN

The complete system is tested and assessed in accordance with BS EN 1634-1:2014 as required by BS 8524-1:2013 for 180 minutes Integrity, and 30 minutes Radiation (up to 5m in height) and 120 minutes Integrity, and 30 minutes Radiation (up to 8m in height).

Classified as E180 EW30 C1 for up to 5m in height and E120 EW30 C1 for up to 8m in height in accordance with BS EN 13501-2:2007+A1:2009.

Fabric is tested independently to reaction to fire tests in accordance with BS EN ISO 1716 and classified as A1 in accordance with BS EN 13501-1+A1

The system is third party certified through the IFC Certification scheme.

SMOKESTOP CONCERTINA

The complete system is tested following the requirements of EN 12101-1:2005+A1:2006 and utilising temperature and pressure conditions of BS EN 1363-1:2012.

The SmokeStop Concertina is classified to DH60 / D60 in accordance with BS EN 13501-4:2007+A1:2009.

The system is CE marked and third party certified through Warrington Fire's Certifire scheme.

All test certificates are available for Download on the Coopers Fire website: www.coopersfire.com

CONTROLS SPECIFICATION

POWER SUPPLY
230V AC 50Hz dedicated supply via all pole isolator

BATTERIES
2 x 12V 12A/h lead acid batteries

ALARM SIGNAL
Normally closed volt-free contacts. Open on activation

TEST FACILITY
Zone Control Panel (ZCP) located on front of Power Supply Unit (PSU)

DISPLAY
Power ON, Alarm ACTIVE and Alarm OFF status LED's on ZCP

POWER SUPPLY SIZE
400mm(w) x 500mm(h) x 210mm(d)

MOTOR CONTROL UNIT SIZE
300mm(w) x 200mm(h) x 80mm(d)

ANCILLARIES

- OBSTRUCTION WARNING SYSTEM (OWS-3)
- SPLIT DROP DELAY
- EMERGENCY RETRACT
- LIGHT WARNING / VOICE WARNING
- BUILDING MANAGEMENT SYSTEM (BMS) INTERFACE

QUALITY ASSURANCE AND CERTIFICATION



MEMBERSHIP



CPD ACCREDITATIONS



For information, to get a quote
or to book a CPD workshop

Please call:

+44 (0)2392 454 405

or E-mail: info@coopersfire.com

WWW.COOPERSFIRE.COM

Coopers Fire Ltd,
Edward House, Penner Road,
Havant, Hampshire, PO9 1QZ
United Kingdom

Phone: +44 (0)2392 454 405
Email: info@coopersfire.com
Web: www.coopersfire.com

Coopers Fire Ltd has a policy of
continuous product improvement.

As such we reserve the right to
change design and specifications
without prior notice.

Please check our website for the
latest information.

© Coopers Fire Ltd. All content and products are copyright
of Coopers Fire Ltd. Registered in England Number: 2010274.

*Multiple patents granted and pending.

Series 2 v09 May 2019



coopers

EST. 1983

LEADING THE WAY IN FIRE PROTECTION